



# Godì 1.8 SP5-D 5U User Manual

Document Version: V1.1  
Release Date: February 2025

## Applicable Model

Model	Cooling
BRB-GI1-508-SP5D-R210	Air Cooling

Copyright © 2025 2CRSi. All rights reserved.

No part of this document may be reproduced or transmitted in any form or by any means without the prior written consent of 2CRSi.

## Environmental Protection

Please dispose of product packaging by recycling at a local recycling center for a greener planet.

## Trademarks

2CRSi and the 2CRSi logo are registered trademarks of 2CRSi.

All other trademarks or registered trademarks mentioned herein may be the property of their respective holders. This document does not mark any product or brand with symbol (® or ™).

## Security Statement

2CRSi is intensely focused on server product safety and has placed a high priority on this. For a better understanding of our server products, carefully read through the following security risk statements.

- When servers are to be repurposed or retired, it is recommended to restore their firmware factory settings, delete information, and clear logs from BIOS and BMC to protect data privacy. Meanwhile, we recommend you wipe the drive data thoroughly and securely with trusted erasing tools.
- For server open-source software statements, please contact 2CRSi Customer Service.
- Some interfaces and commands for production, assembly and return-to-depot, and advanced commands for locating faults, if used improperly, may cause equipment abnormality or business interruption. This is not described herein. Please contact 2CRSi for such information.
- External ports of 2CRSi servers do not use private protocols for communication.
- Our products will not initiatively obtain or use your personal data. Only when you consent to use certain functions or services, some personal data such as IP address and email address for alerts may be obtained or used during business operation or fault location. 2CRSi has implemented necessary measures on product functions to ensure personal data security throughout the data lifecycle, including but not limited to data collection, storage, use, transmission, and destruction. Meanwhile, you are obligated to establish necessary user privacy policies in accordance with applicable national/regional laws and regulations to fully protect user personal data.
- Committed to product data security, 2CRSi has implemented necessary

measures on product functions to protect system operation and security data throughout its lifecycle in strict accordance with relevant laws, regulations and supervision requirements. As the owner of system operation and security data, you are obligated to establish necessary data security policies and take adequate measures in accordance with applicable national/regional laws and regulations to fully protect system operation and security data.

- 2CRSi will remain committed to the safety of our products and solutions to achieve better customer satisfaction. 2CRSi has established emergency response procedures and action plans for security vulnerabilities, so that product safety issues can be dealt with in a timely manner. Please contact 2CRSi Customer Service for any safety problems found or necessary support on security vulnerabilities when using our products.

## Disclaimer

The purchased products, services and features shall be bound by the contract made between 2CRSi and the customer. All or part of the products, services and features described herein may not be within your purchase or usage scope. Unless otherwise agreed in the contract, 2CRSi makes no express or implied statement or warranty on the contents herein. Images provided herein are for reference only and may contain information or features that do not apply to your purchased model. This manual is only used as a guide. 2CRSi shall not be liable for any damage, including but not limited to loss of profits, loss of information, interruption of business, personal injury, or any consequential damage incurred before, during, or after the use of our products. 2CRSi assumes you have sufficient knowledge of servers and are well trained in protecting yourself from personal injury or preventing product damages during operation and maintenance. The information in this manual is subject to change without notice. 2CRSi shall not be liable for technical or editorial errors or omissions contained in this manual.

## Technical Support





Global Service Hotline:	+33 (0) 3 68 41 10 60
Address:	32 Rue Jacobi-Netter, 67200 Strasbourg, France
Email:	support@2crsi.com

# Preface

---

## Symbol Conventions

The symbols that may be found in this document are defined as follows.

Symbol	Description
 DANGER	A potential for serious injury, or even death if not properly handled
 WARNING	A potential for minor or moderate injury if not properly handled
 CAUTION	A potential loss of data or damage to equipment if not properly handled
 IMPORTANT	Operations or information that requires special attention to ensure successful installation or configuration
 NOTE	Supplementary description of document information

## Revision History

Version	Date	Description of Changes
V1	2025/11/30	Initial release
V1.1	2025/11/31	Technical Validation
V2.0	2026/13/02	Document update

## Table of Contents

<b>1.</b>	<b><i>Product Overview</i></b> .....	<b>6</b>
<b>2.</b>	<b><i>Features</i></b> .....	<b>6</b>
2.1.	Expandability and Performance .....	6
2.2.	Expandability Availability and Serviceability .....	7
2.3.	Manageability and Security .....	7
<b>3.</b>	<b><i>System Logical Diagram</i></b> .....	<b>9</b>
<b>4.</b>	<b><i>Hardware Description</i></b> .....	<b>10</b>
4.1.	Front panel .....	10
4.2.	Network.....	10
4.3.	I/O Expansion .....	10
4.3.1	PCIe Expansion Card.....	11
4.4.	Motherboard .....	13
<b>5.</b>	<b><i>Components replacement</i></b> .....	<b>16</b>
5.1.	DIMM Replacement .....	16
5.2.	CPU Replacement.....	19
5.3.	PCIe Expansion Card Replacement .....	21
5.4.	Power Supply Replacement .....	22
<b>6.</b>	<b><i>System Specifications</i></b> .....	<b>24</b>
<b>7.</b>	<b><i>Operating System and Hardware Compatibility</i></b> .....	<b>25</b>
<b>8.</b>	<b><i>Operating System and Hardware Compatibility</i></b> .....	<b>25</b>
8.1.	Supported Operating Systems .....	25
8.2.	Hardware Compatibility .....	26
8.2.2	CPU Specifications.....	26
8.2.3	DIMM Specifications .....	27
8.2.4	NIC Specifications.....	28
<b>9.</b>	<b><i>Regulatory Information</i></b> .....	<b>30</b>
9.1.	Safety .....	30
9.1.1	General.....	30
9.1.2	Personal Safety .....	30
9.1.3	Equipment Safety .....	32
9.1.4	Transportation Precautions .....	32
9.1.5	Manual Handling Weight Limits.....	32

# 1. Product Overview

The Godi 1.8 SP5D is a 5U dual-socket server powered by 4th and 5th Gen AMD EPYC™ 9004/9005 series processors, supporting up to four accelerators.

Designed for high-density computing, it combines high core counts, exceptional memory bandwidth, and ultra-high I/O throughput to deliver efficient, high-performance computing for demanding workloads.

Built with reliability and quality at its core, the system is engineered to perform consistently across a wide range of deployment scenarios. In addition, it offers outstanding performance, extensive expansion capabilities, broad ecosystem compatibility, and simplified operations, management, and maintenance.

## 2. Features

### 2.1. Expandability and Performance

- Features the 4<sup>th</sup> (Genoa) and 5th Gen AMD EPYC 9005 (Turin) processors, with up to 192 cores per processor (384 threads) for the dense-core (“Zen 5c”) variant, a TDP up to 500 W, boost frequencies up to 5.0 GHz, an L3 cache up to 512 MB (for select SKUs), and support for up to 12-channel DDR5 memory plus PCIe Gen5, delivering exceptional processing performance.
  - Up to 1 processor, 192 cores and 384 threads per socket, maximizing concurrent execution of massively multithreaded workloads.
  - Increased L2 cache. Each core has a private L2 cache of 1 MB.
  - Turbo Core technology brings you an intelligent self-adaptation system. It allows the CPU cores to exceed the processor TDP at peak workload and run at the maximum frequency.
  - Hyper-threading technology allows every processor core to run multiple threads (up to 2 threads per core) concurrently, improving the performance of multi-threaded applications.
  - AMD Virtualization (AMD-V) technology integrates hardware-level virtualization features, allowing the operating system to better leverage hardware to handle virtualized workloads.
  - Advanced Vector Extensions 512 (AVX-512), an instruction set, can significantly improve the floating-point performance for compute-intensive workloads.
- Up to 24 DDR5 DIMMs.
  - Up to 24 DDR5 ECC RDIMMs (4,800 MT/s) for superior speed, high availability, and a memory capacity up to 3,072 GB, with a theoretical memory bandwidth of 900 GB/s.

- Infinity Fabric technology, IOD and PCIe 5.0 controllers are integrated into processors, significantly shortening I/O latency and enhancing overall system performance.
- Up to 2 standard PCIe slots for HHHL cards
- Supports up to 8 PCIe slots for FHFL accelerator cards up to 600W, including NVIDIA H200 NVL and RTX 6000 Blackwell GPUs.

## 2.2. Expandability Availability and Serviceability

- SSDs are much more reliable than traditional HDDs, increasing system uptime.
- The UID and status LEDs for fault diagnosis on the front panel, and the BMC Web GUI indicate the status of key components and quickly lead technicians to failed (or failing) components, simplifying maintenance, speeding up troubleshooting, and enhancing system availability.
- The IPMI management port on the rear panel enables you to directly access the IPMI and supports local O&M, improving O&M efficiency.
- The onboard BMC monitors system parameters in time and sends alerts in advance, so that technicians can take corresponding measures in time to ensure stable operation and minimize system downtime.
- 2CRSi's unique intelligent control technology combined with the cutting-edge air-cooling technology creates an optimum working environment for stable running of the server.

For documentation of the system (such as product marketing materials, user manuals, product drivers, firmware, and product certifications), visit 2CRSi website: <https://2crsi.com>

## 2.3. Manageability and Security

- The BMC integrated in the server can monitor the server status and manage the server remotely.
- Network Controller Sideband Interface (NC-SI) feature allows a network port to serve as a management port and a service port. This feature can be enabled/disabled in the IPMI Web GUI or BIOS. It is disabled by default.
- Industry-standard Unified Extensible Firmware Interface (UEFI) improves the efficiency of setup, configuration, and update, and simplifies error handling.
- Trusted Platform Module (TPM) 2.0 and Trusted Cryptography Module (TCM) provide advanced encryption.
- AMD Secure Processor (ASP), an integrated on-chip security processor, helps protect sensitive data and validate code before it is executed. It helps protect your system & data from unauthorized software and applications running on

your device.

- AMD Secure Encrypted Virtualization (AMD SEV) protects Linux KVM virtual machines by transparently encrypting the memory of each VM with a unique key.
- Firmware update mechanisms based on digital signatures prevents unauthorized firmware updates.
- UEFI Secure Boot protects the system from malicious boot loaders.
- Hierarchical password protection in BIOS ensures system boot and management security.
- BIOS Secure Flash and BIOS Lock Enable (BLE) reduces attacks from malicious software on the BIOS flash region.
- Dual-image mechanism for BMC and BIOS recovers firmware upon detection of firmware damage.
- BMC Secure Boot protects BMC from malicious tampering.
- Flexible BMC access control policies improve BMC management security.



The NC-SI port supports the following features:

- The NC-SI port can be bonded to any network port of the OCP card or of PCIe NIC that supports NC-SI.
  - Supports the enable/disable and configuration of Virtual Local Area Network ID (VLAN ID). VLAN is disabled by default and the default VLAN ID is 0.
  - Supports IPv6 and IPv4 addresses. IP address, subnet mask, default gateway, and prefix length of IPv6 address can be configured.
-

# 3. System Logical Diagram

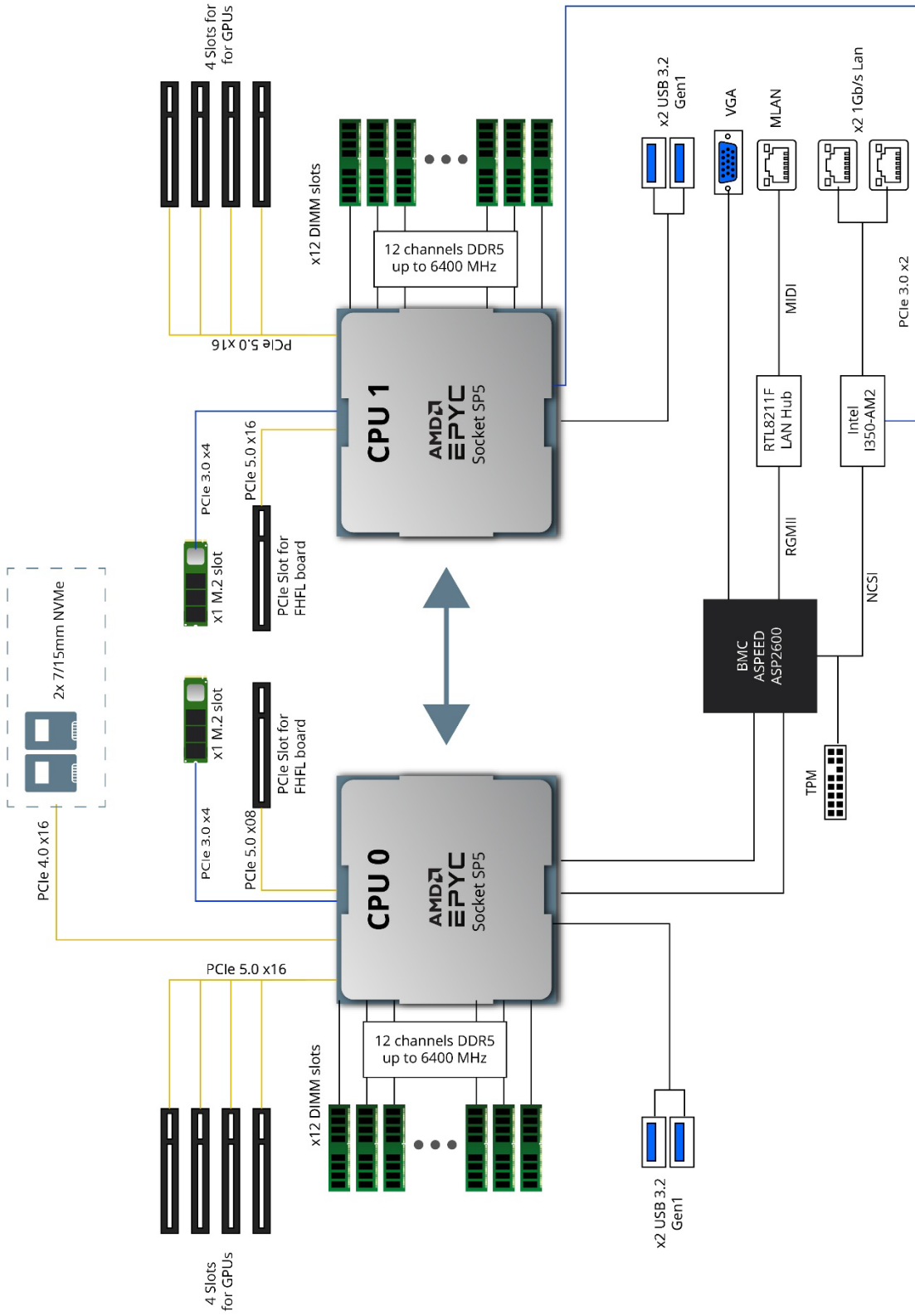

## 4. Hardware Description

### 4.1. Front panel



Item	Feature	Item	Feature
1	X4 USB 3.2 ports	4	2x RJ45
2	X1 VGA Port		
3	1x RJ 45 dedicated IPMI		

### 4.2. Network

NICs provide network expansion capabilities.

- The PCIe slots support PCIe NICs. Users can select the cards as needed.
- For specific NIC options, consult your local 2CRSi sales representative or refer to 7.2 Hardware Compatibility.

### 4.3. I/O Expansion

### 4.3.1 PCIe Expansion Card

The PCIe cards provide system expansion capabilities.

- For specific PCIe expansion card options, consult your local 2CRSi sales representative or refer to 7.2 Hardware Compatibility.

## PCIe Slot Layout



- X2 HHHL slots for addon PCIe card reside at the front of the server Slots #0 & #1.
- X8 FHFL Slots for accelerators reside at the rear of the server Slot #2 to Slot #9.

## Accelerator replacement

---

 CAUTION

- The accelerators delivered with the servers have a modified cooling system, optimized for dual-phase cooling.
- To maintain the warranty and avoid any issues, all modifications must be carried out by 2CRSi.

- Please contact us if you wish to proceed with any changes.

---

PCIe Slot	PCIe Standard	Connect or Width	Bus Width	Form Factor
Slot 0	PCIe 5.0	x16	x16	HHHL
Slot 1	PCIe 5.0	x16	x16	HHHL
Slot 2	PCIe 5.0	x16	x16	FHFL
Slot 3	PCIe 5.0	x16	x 16	FHFL
Slot 4	PCIe 5.0	x16	x 16	FHFL
Slot 5	PCIe 5.0	x16	x 16	FHFL
Slot 6	PCIe 5.0	x16	x 16	FHFL
Slot 7	PCIe 5.0	x16	x 16	FHFL
Slot 8	PCIe 5.0	x16	x 16	FHFL
Slot 9	PCIe 5.0	x16	x 16	FHFL

# 4.4. Motherboard

## MOTHERBOARD LAYOUT

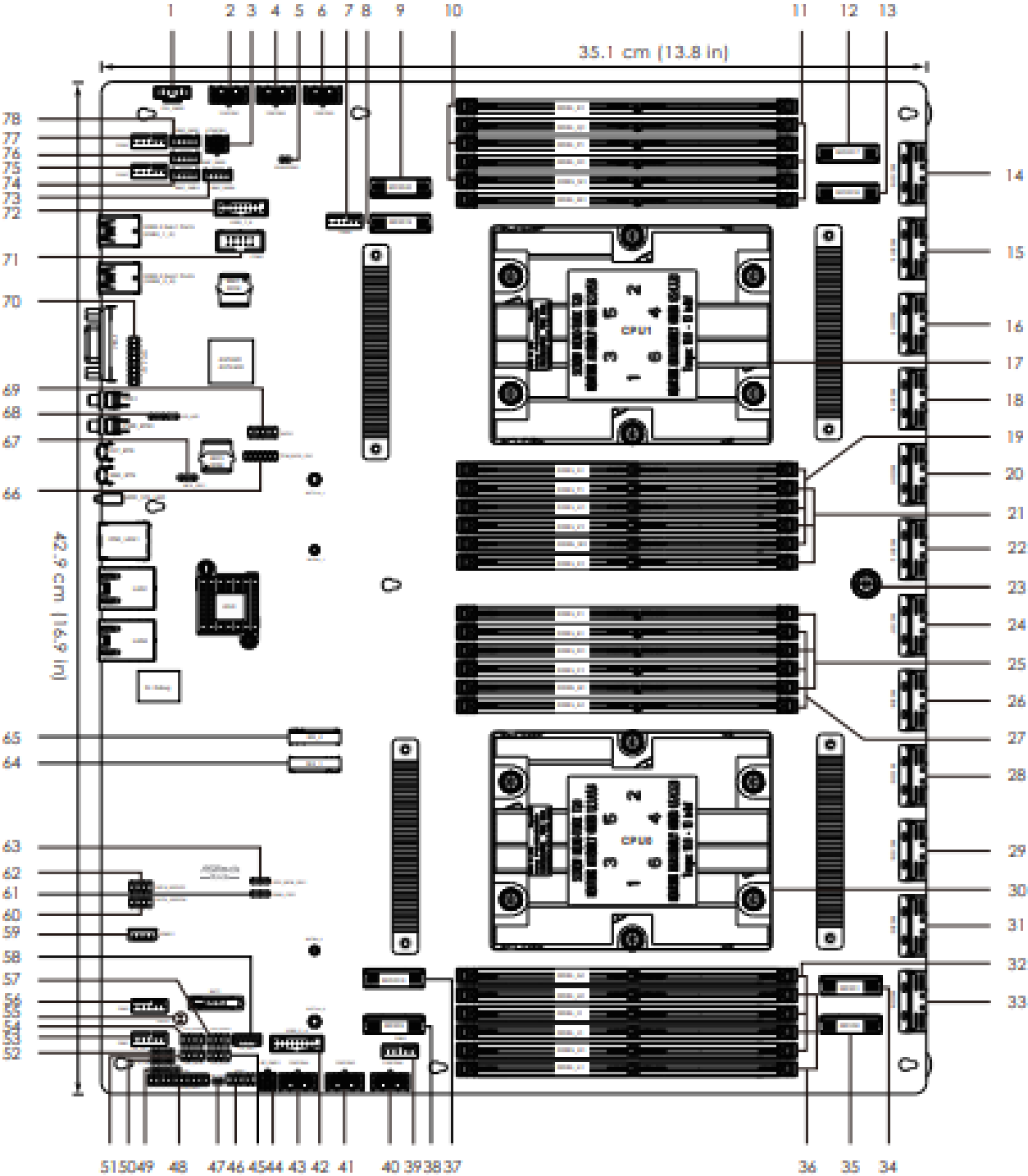

Number	Description	Number	Description
1	PSU SMBus Header (PSU_SMB1)	37	Mini Cool Edge IO Connector (MCIO10)
2	ATX 12V Power Connector (12VCON1)	38	Mini Cool Edge IO Connector (MCIO9)
3	Micro-Fit Power Connector (ATX4PIN1)	39	System Fan Connector (FAN3)
4	ATX 12V Power Connector (12VCON2)	40	ATX 12V Power Connector (12VCON6)
5	Chassis Intrusion Header (CASEOPEN1)	41	ATX 12V Power Connector (12VCON5)
6	ATX 12V Power Connector (12VCON3)	42	USB 3.2 Gen1 Header (USB3_5_6)
7	System Fan Connector (FAN4)	43	ATX 12V Power Connector (12VCON4)
8	Mini Cool Edge IO Connector (MCIO19)	44	System Power Connector (BP_PWR1)
9	Mini Cool Edge IO Connector (MCIO20)	45	SATA SGPIO Connector (SATA_SGPIO1)
10	3 x 288-pin DDR5 DIMM Slots (DDR5_N1, DDR5_P1, DDR5_R1)*	46	System Panel Header (PANEL1)
11	3 x 288-pin DDR5 DIMM Slots (DDR5_M1, DDR5_O1, DDR5_Q1)*	47	Non Maskable Interrupt Button (NMI_BTN1)
12	Mini Cool Edge IO Connector (MCIO17)	48	Auxiliary Panel Header (AUX_PANEL1)
13	Mini Cool Edge IO Connector (MCIO18)	49	Liquid Crystal Module Header (LCM1)
14	Mini Cool Edge IO Connector (MCIO15)	50	Rear Panel LAN LED (RL_LED)
15	Mini Cool Edge IO Connector (MCIO16)	51	SATA SGPIO Connector (SATA_SGPIO3)
16	Mini Cool Edge IO Connector (MCIO13)	52	IPMI LAN LED Header (IPMI_LED1)
17	AMD Socket SP5 (SM-LGA-6096) (CPU1)	53	System Fan Connector (FAN1)
18	Mini Cool Edge IO Connector (MCIO14)	54	SATA SGPIO Connector (SATA_SGPIO4)
19	3 x 288-pin DDR5 DIMM Slots (DDR5_S1, DDR5_U1, DDR5_W1)*	55	Clear CMOS Pad (CLR MOS1)
20	Mini Cool Edge IO Connector (MCIO11)	56	System Fan Connector (FAN2)
21	3 x 288-pin DDR5 DIMM Slots (DDR5_T1, DDR5_V1, DDR5_X1)*	57	SATA SGPIO Connector (SATA_SGPIO2)
22	Mini Cool Edge IO Connector (MCIO12)	58	Backplane PCI Express Hot-Plug Connector (CPU_HSBP1)
23	Thumbscrew	59	Intelligent Platform Management Bus Header (IPMB1)
24	Mini Cool Edge IO Connector (MCIO7)	60	SATA SGPIO Connector (SATA_SGPIO6)
25	3 x 288-pin DDR5 DIMM Slots (DDR5_B1, DDR5_D1, DDR5_F1)*	61	PWM Configuration Header (PWM_CFG1)
26	Mini Cool Edge IO Connector (MCIO8)	62	SATA SGPIO Connector (SATA_SGPIO5)
27	3 x 288-pin DDR5 DIMM Slots (DDR5_A1, DDR5_C1, DDR5_E1)*	63	PCIe Signal Source Selection Jumper (PCIE_BCM_SEL1)
28	Mini Cool Edge IO Connector (MCIO5)	64	M.2 Socket (M2_1) (Type 2280/22110)
29	Mini Cool Edge IO Connector (MCIO6)	65	M.2 Socket (M2_2) (Type 2280/22110)
30	AMD Socket SP5 (SM-LGA-6096) (CPU0)	66	SPI TPM Header (TPM_BIOS_PH1)
31	Mini Cool Edge IO Connector (MCIO3)	67	NCSI Mode Jumper (NCSI_SEL1)
32	3 x 288-pin DDR5 DIMM Slots (DDR5_G1, DDR5_I1, DDR5_K1)*	68	UID Button Header (UID_HD1)
33	Mini Cool Edge IO Connector (MCIO4)	69	NCSI Header (NCSI1)
34	Mini Cool Edge IO Connector (MCIO1)	70	Front VGA Header (FRNT_VGA1)
35	Mini Cool Edge IO Connector (MCIO2)	71	COM Port Header (COM1)
36	3 x 288-pin DDR5 DIMM Slots (DDR5_H1, DDR5_J1, DDR5_L1)*	72	USB 3.2 Gen1 Header (USB3_7_8)

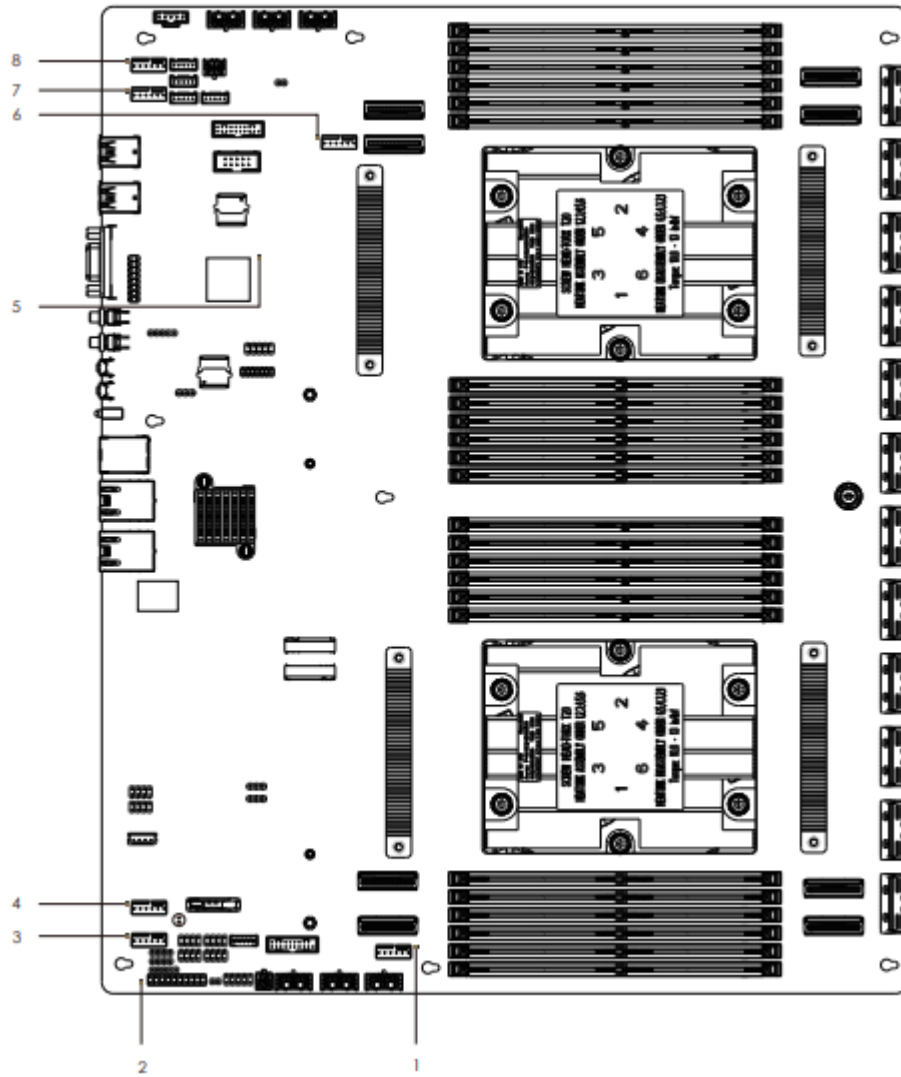

No.	Item	Status	Description
1	LED_FAN3	Red	FAN3 failed
2	SB_PWR1	Green	STB PWR ready
3	LED_FAN1	Red	FAN1 failed
4	LED_FAN2	Red	FAN2 failed
5	BMC_LED1	Green	BMC heartbeat LED
6	LED_FAN4	Red	FAN4 failed
7	LED_FAN5	Red	FAN5 failed
8	LED_FAN6	Red	FAN6 failed

# 5. Components replacement

---



Remember to remove the labels from the components before integrating them, to prevent them from peeling off and contaminating the immersion tank.

---

## 5.1. DIMM Replacement

This motherboard provides twenty-four 288-pin DDR5 (Double Data Rate 5) DIMM slots in two groups, and supports Single Channel Memory Technology

CPU 0	CPU 1
DDR5_M1, N1, O1, P1, Q1, R1	DDR5_A1, B1, C1, D1, E1, F1
DDR5_S1, T1, U1, V1, W1, X1	DDR5_G1, H1, I1, J1, K1, L1

---



It is not allowed to install a DDR, DDR2, DDR3 or DDR4 memory module into a DDR5 slot; otherwise, this motherboard and DIMM may be damaged.

For Single channel configuration, it always needs to install identical (the same brand, speed, size and chip-type) DDR5 DIMMs.

---

**RECOMMENDED MEMORY CONFIGURATION**

Number of Memory Channels Populated	Number of CPU Installed	AMD Recommended Memory Channels																											
		CPU0														CPU1													
		A1	B1	C1	D1	E1	F1	G1	H1	I1	J1	K1	L1	M1	N1	O1	P1	Q1	R1	S1	T1	U1	V1	W1	X1				
24	2P	V	V	V	V	V	V	V	V	V	V	V	V	V	V	V	V	V	V	V	V	V	V	V	V	V	V		
	1P																												
20	2P	V	V	V	V	V	V	V	V	V	V	V	V	V	V	V	V	V	V	V	V	V	V	V	V	V	V		
	1P																												
16	2P	V	V	V	V	V	V	V	V	V	V	V	V	V	V	V	V	V	V	V	V	V	V	V	V	V	V		
	1P																												
12	2P	V	V	V	V	V	V	V	V	V	V	V	V	V	V	V	V	V	V	V	V	V	V	V	V	V	V		
	1P	V	V	V	V	V	V	V	V	V	V	V	V	V	V	V	V	V	V	V	V	V	V	V	V	V	V		
10	2P																												
	1P	V	V	V	V	V	V	V	V	V	V	V	V	V	V	V	V	V	V	V	V	V	V	V	V	V	V		
8	2P	V	V	V	V	V	V	V	V	V	V	V	V	V	V	V	V	V	V	V	V	V	V	V	V	V	V		
	1P	V	V	V	V	V	V	V	V	V	V	V	V	V	V	V	V	V	V	V	V	V	V	V	V	V	V		
6	2P																												
	1P	V	V	V	V	V	V	V	V	V	V	V	V	V	V	V	V	V	V	V	V	V	V	V	V	V	V		
4	2P	V	V	V	V	V	V	V	V	V	V	V	V	V	V	V	V	V	V	V	V	V	V	V	V	V	V		
	1P	V	V	V	V	V	V	V	V	V	V	V	V	V	V	V	V	V	V	V	V	V	V	V	V	V	V		
2	2P	V	V	V	V	V	V	V	V	V	V	V	V	V	V	V	V	V	V	V	V	V	V	V	V	V	V		
	1P	V	V	V	V	V	V	V	V	V	V	V	V	V	V	V	V	V	V	V	V	V	V	V	V	V	V		
1	2P																												
	1P	V	V	V	V	V	V	V	V	V	V	V	V	V	V	V	V	V	V	V	V	V	V	V	V	V	V		

### To remove the DIMM:

1. Locate the DIMM you want to replace.
2. Remove the DIMM:
  - a. Push the release tabs on both ends of the DIMM slot outward to unlock it. Gently lift and remove the DIMM from the slot



Make sure the release tabs on both sides of the DIMM slot are fully opened.

---

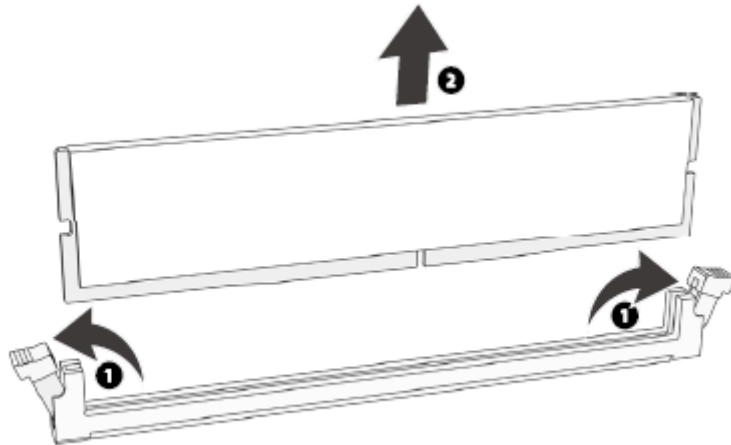

- b. Push the release tabs on both ends of the DIMM slot outward to unlock it. Gently lift and remove the DIMM from the slot

### To install the DIMM:

1. Take the new DIMM out from the memory box.
2. Align the bottom notch with the receptive point on the slot. Use two thumbs together to press both ends of the module straight down into the slot until the module snaps into place.

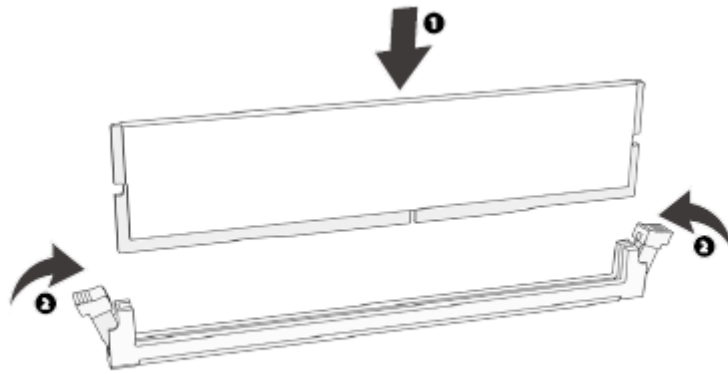

## 5.2. CPU Replacement

---



CAUTION

The CPUs delivered with the servers have a modified cooling system, optimized for dual-phase cooling.

To maintain the warranty and avoid any issues, all modifications must be carried out by 2CRSi. Please contact us if you wish to proceed with any changes.

---

1. Remove the heatsink Module.
  - a. Push the release tabs on both ends of the DIMM slot outward to unlock it. Gently lift and remove the DIMM from the slot

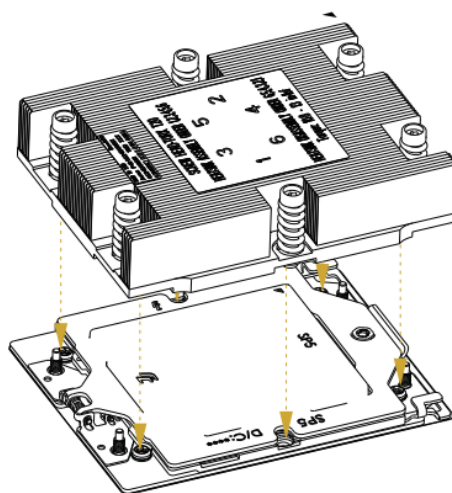



The gold pins on the CPU are fragile and can be easily damaged if touched. During removal and installation, always keep the gold pins up and DO NOT touch the pins when processor dedicated insertion/removal tool (CPU tray) is unavailable.

---

- b. Loosen the screw securing the top cover of CPU socket anticlockwise and remove the top cover.

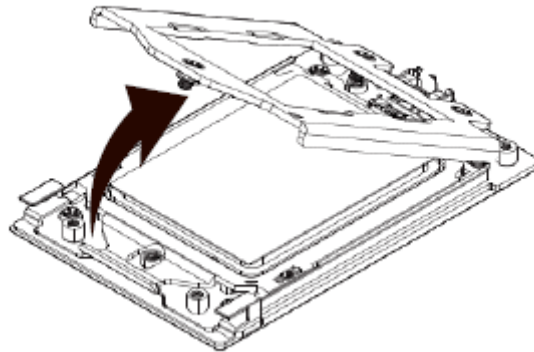

- c. Open the tabs on both sides and lift up the inner bracket. Gently remove the CPU and put it into an antistatic bag.

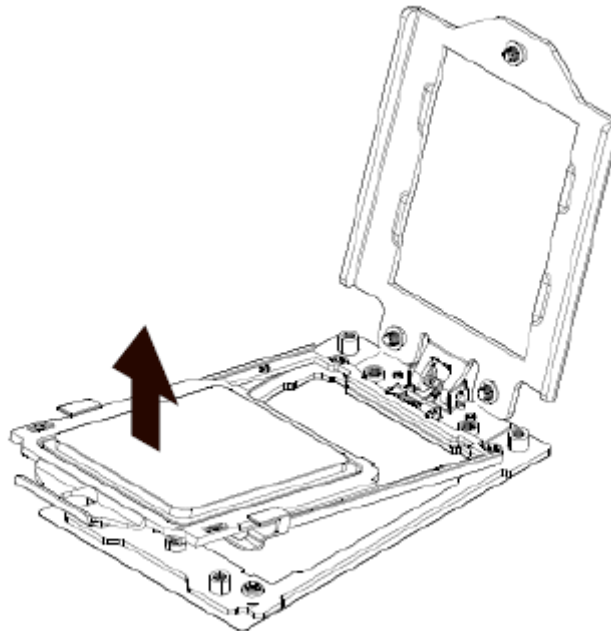



- Use a clean and lint-free cloth to wipe off the old thermal grease first if the heatsink is to be reused.
  - Apply compatible thermal interface material onto the heatsink before reusing the heatsink.
- 

2. Install the processor heatsink module:
  - a. Put the CPU back into the inner bracket, and make sure that the gold pins of the CPU do not touch the bracket until it snaps into place.
  - b. Gently put the CPU socket onto the base and press it down on both sides until it snaps into place.
  - c. Close the top cover and tighten the screws screwing the top cover to the CPU socket.
  - d. Evenly apply a compatible thermal interface material that covers the CPU fully.
  - e. To install the heatsink: Tighten the four screws securing the PHM to the CPU socket clockwise in the sequence as shown on the heatsink label with a T30 Torx screwdriver.

## 5.3. PCIe Expansion Card Replacement

---



- To prevent damage to the server or expansion cards, power down the server and remove all power cables before removing or installing the PCIe card.
  - To prevent damage to the PCIe slot pins, be sure to apply even force and pull and insert the PCIe card vertically.
- 

To remove the PCIe expansion card:

1. Disconnect the cables of the riser card.
2. Loosen the screws located atop the bracket.
3. Gently lift and remove the PCIe riser card assembly with both hands.

4. Disconnect the cables of the riser card. Take a record of the cables to avoid wrong cabling when installing.
5. Remove the PCIe card from the assembly.

To install the PCIe expansion card:

1. Remove the new PCIe card from the antistatic bag.
2. Align and insert it into the riser card slot.
3. Align and insert the riser card assembly into the motherboard slot.
4. Connect the remaining cables for the riser card.
5. Securely tighten the screws on the bracket's top.

## 5.4. Power Supply Replacement

To reduce the risk of personal injury from hot surfaces, allow the power supply or power supply blank to cool down before touching.



CAUTION

To prevent improper cooling and thermal damage, do not operate the server unless all bays are populated with either a component or a blank.

---

To remove the PSU:

1. Press the PSU release tab and hold the handle to pull out the PSU horizontally.

**FIGURE 4-33 REMOVING THE PSU**

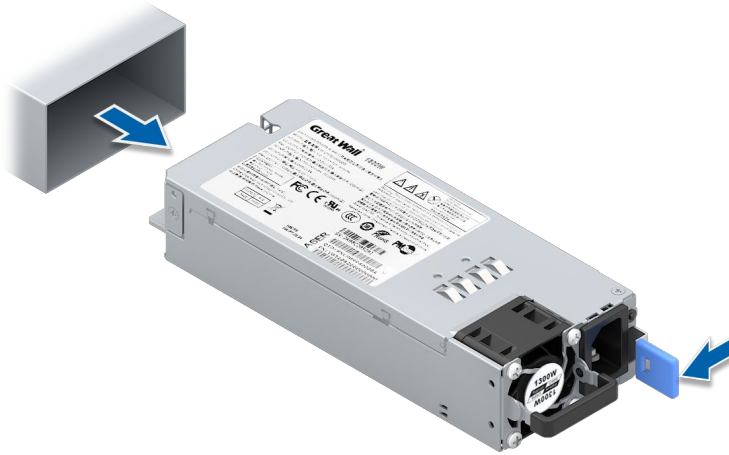

1. Put it into an anti-static bag.

To install the PSU:

2. Take a new PSU from the anti-static bag.
3. Hold the handle and push the PSU into the power supply bay until it is in place.
4. Check that the PSU LED is solid green.



CAUTION

Please note that we use power supplies specifically designed for immersion.  
If you wish to replace them, please contact 2CRSi.

---

# 6. System Specifications

## SPECIFICATIONS

<b>System</b>	<b>Model</b>	Godi 1.8 SP5-D
	<b>Form factor</b>	19" - 5U
	<b>Dimension</b>	(D) 820mm × (W) 447mm × (H) 230mm
	<b>Cooling technology</b>	Air cooling
	<b>TDP max per chip</b>	CPU 500 W / GPU 600W
<b>Storage</b>	<b>Internal type</b>	2 M.2 slots (SATA/PCIe3.0x1) for
	<b>External type</b>	8 hot-swappable 3.5/2.5" SAS/SATA/NVMe hard drives
<b>Motherboard</b>	<b>CPU</b>	Dual AMD EPYC™ 9xx5/9xx4 Turin, Genoa, Bergamo and Genoa-X with AMD 3D V-Cache™ Technology Series Processor families, up to 160-core, 320 threads per processor, cTDP up to 400W
	<b>Chipset</b>	System on chip
	<b>Expansion slots</b>	8x PCIe 5.0 x16 for GPUs (2 Slots) 4x PCIe 5.0 x8 HH-HL for NIC or RAID Controller
<b>Memory</b>	<b>Total slots</b>	24 slots
	<b>Capacity</b>	RDIMM: 128GB (2Rx4), 3.0TB total RDIMM-3DS: 512GB (2Rx4), 12.0TB total
	<b>Memory type</b>	DDR5 6000 MHz (1DPC)
<b>Network</b>	<b>Onboard</b>	1x 1GbE Management Port dedicated to the IPMI 2x 1GbE Intel®i350
	<b>NIC Options</b>	2x 25GbE (SFP28), 900-9X662-0053-ST1 2x 100GbE (QSFP112), 900-9X7AH-0086-SQ0 2x 200GbE or NDR200 (QSFP112), 900-9X7AH-0079-DTZ 1x 400Gb or NDR400 (QSFP112), 900-9X7AH-0039-STZ 1x 400Gb or NDR400 (QSFP), 900-9X721-003N-DT0
<b>I/O</b>	<b>Front</b>	1x Serial Port 2x USB 3.0 1xVGA 1x RJ45 1*2x optional 2x10G RJ45 dedicated IPMI
	<b>Rear</b>	
<b>Management Solution</b>	<b>Software</b>	ASPEED AST2600
	<b>Out of band remote management</b>	WebGUI, Intelligent Platform Management Interface (IPMI)
<b>Power Supply</b>	<b>Type</b>	4+1 redundant 2000W Platinum CRPS power supply
	<b>Power rating</b>	2000W
	<b>Power efficiency</b>	Platinum/Titanium
<b>Operating Environment</b>	<b>Operating Temperature</b>	Operation temperature: 10°C ~ 35°C (50°F ~ 95°F)
	<b>Non-operating Temperature</b>	Non operation temperature: -40°C ~ 60°C (40° ~ 140°F)
	<b>Operating Relative Humidity</b>	95%, non-condensing at 35° C
<b>Warranty</b>	2CRSi hardware warranty includes a one year, parts and labour with return to 2CRSi selling entity. Customers may purchase an extended warranty of up to 3 years on parts and labour with different support levels. Please contact 2CRSi at <a href="mailto:support@2crsi.com">support@2crsi.com</a> or reach your sales point of contact for complete warranty details including limitations and transferability. <a href="https://2crsi.com/global-location">2crsi.com/global-location</a>	

## 7. Operating System and Hardware Compatibility

This section describes the OS and hardware compatibility of the server. For the latest compatibility configuration and the component models not listed in this document, contact your local 2CRSi sales representative.

---



- Using incompatible components may cause the server to work abnormally, and such failures are not covered by technical support or warranty.
  - The server performance is strongly influenced by application software, middleware and hardware. The subtle differences in them may lead to performance variation in the application and test software.
    - For requirements on the performance of specific application software, contact 2CRSi sales representatives to request proof of concept (POC) and confirm the detailed hardware and software configurations during the pre-sales phase.
    - For requirements on hardware performance consistency, define specific configuration requirements (for example, specific drive models, RAID controller cards, or firmware versions) during the pre-sales phase.
- 

## 8. Operating System and Hardware Compatibility

### 8.1. Supported Operating Systems

#### SUPPORTED OPERATING SYSTEMS:

OS	OS Version
Windows	Windows Server 2019
Red Hat	Red Hat Enterprise Linux 8.6
	Red Hat Enterprise Linux 9.0
VMware	VMware ESXi 7.0 P06

## 8.2. Hardware Compatibility

### 8.2.2 CPU Specifications

#### 8.2.3

MODEL	CORES	THREADS	BASE FREQ. (GHZ)	UP TO BOOST (GHZ) <sup>a</sup>	MAX FREQ.	DEFAULT TDP (W)	L3 CACHE (MB)	2P/1P
9965	192	384	2.25 GHz	3.7 GHz		500W	384 MB	2P/1P
9845	160	320	2.1 GHz	3.7 GHz		390W	320 MB	2P/1P
9825	128	256	2.2 GHz	3.7 GHz		390W	384 MB	2P/1P
9755	128	256	2.7 GHz	4.1 GHz		500W	512 MB	2P/1P
9745	128	256	2.4 GHz	3.7 GHz		400W	256 MB	2P/1P
9655P	96	192	2.6 GHz	4.5 GHz		400W	384 MB	1P
9655	96	192	2.6 GHz	4.5 GHz		400W	384 MB	2P/1P
9645	96	192	2.3 GHz	4.5 GHz		320W	256 MB	2P/1P
9575F	64	128	3.3 GHz	5 GHz		400W	256 MB	2P/1P
9565	72	144	3.15 GHz	4.3 GHz		400W	384 MB	2P/1P
9555P	64	128	3.2 GHz	4.4 GHz		360W	256 MB	1P
9555	64	128	3.2 GHz	4.4 GHz		360W	256 MB	2P/1P
9535	64	128	2.4 GHz	4.4 GHz		300W	256 MB	2P/1P
9475F	48	96	3.65 GHz	4.8 GHz		400W	256 MB	2P/1P
9455P	48	96	3.15 GHz	4.4 GHz		300W	256 MB	2P/1P
9455	48	96	3.15 GHz	4.4 GHz		300W	256 MB	2P/1P
9375F	32	64	3.8 GHz	4.8 GHz		320W	192 MB	2P/1P
9365	36	72	3.65 GHz	4.8 GHz		300W	192 MB	2P/1P
9355P	32	64	3.55 GHz	4.4 GHz		280W	256 MB	1P
9355	32	64	3.55 GHz	4.4 GHz		280W	256 MB	2P/1P
9335	32	64	3.55 GHz	4.4 GHz		280W	256 MB	2P/1P
9275F	24	48	4.1 GHz	4.8 GHz		210W	128 MB	2P/1P
9255	24	48	3.2 GHz	4.8 GHz		200W	256 MB	2P/1P
9175F	16	32	4.2 GHz	5 GHz		320W	512 MB	2P/1P
9135	16	32	3.65 GHz	4.3 GHz		200W	64 MB	2P/1P
9115	16	32	2.6 GHz	4.1 GHz		125W	64 MB	2P/1P
9015	8	16	3.6 GHz	4.1 GHz		125W	64 MB	2P/1P
9754	128	256	2.25	3.10	360	256	2P/1P	
9754S		128						
9734	112	224	2.20	3.00	340	256	2P/1P	
9654	96	192	2.40	3.70	360	384	2P/1P	
9654P							1P	
9634	84	168	2.25	3.70	290	384	2P/1P	
9554	64	128	3.10	3.75	360	256	2P/1P	
9554P							1P	
9534	64	128	2.45	3.70	280	256	2P/1P	

9454	48	64	2.75	3.80	290	256	2P/1P
9454P							1P
9354	32	64	3.25	3.80	280	256	2P/1P
9354P							1P
9334	32	56	2.70	3.90	210	128	2P/1P
9254	24	48	2.90	4.15	200	128	2P/1P
9224	24	48	2.50	3.70	200	64	2P/1P
9124	16	32	3.00	3.70	200	64	2P/1P
9684X	96	192	2.55	3.70	400	1152	2P/1P
9384X	32	64	3.10	3.90	320	768	2P/1P
9184X	16	32	3.55	4.20	320	768	2P/1P
9474F	48	96	3.60	4.10	360	256	2P/1P
9374F	32	64	3.85	4.30	320	256	2P/1P
9274F	24	48	4.05	4.30	320	256	2P/1P
9174F	16	32	4.10	4.40	320	256	2P/1P

## 8.2.1 GPU Specifications

Vendor	Part number	Name
NVIDIA	900-21010-0040-000	NVIDIA H200 NVL
NVIDIA	VCNRTXPRO6000-PB	RTX 6000 Pro Blackwell
NVIDIA	VCNRTXPRO5000-PB	RTX 5000 Pro Blackwell
NVIDIA	VCNRTXPRO4500-PB	RTX 4500 Pro Blackwell
NVIDIA	VCNRTXPRO4000-PB	RTX 4000 Pro Blackwell

## 8.2.2 DIMM Specifications

The server supports up to 32 DDR5 DIMMs. Each processor supports 12 memory channels with up to 2 DIMMs per channel. The supported DIMMs includes RDIMMs and CPS.

### DIMM SPECIFICATIONS

Type	Capacity (GB)	Frequency (MHz)	Data Width	Organization
RDIMM	16	4,800	x80	1R x8
RDIMM	32	4,800	x80	1R x4/2R x8
RDIMM	64	4,800	x80	2R x4
CPS	128	4,800		

## 8.2.3 NIC Specifications

### NIC SPECIFICATIONS

Vendor	Part number	Name	Port speed	I/O	Host I/F
Broadcom	BCM957508-P2100G	P2100G	2× 100GbE	QSFP56	PCIe 4.0 x16
Broadcom	BCM957414A4140C	P150p	1× 50GbE	SFP28	PCIe 3.0 x8
Broadcom	BCM957504-P425G	P425G	4× 25GbE	SFP28	PCIe 4.0 x16
Broadcom	BCM957414A4142CC	P225p	2× 25GbE/10GbE	SFP28	PCIe 3.0 x8
Broadcom	BCM957412A4120AC	P210P	2× 10GbE	SFP+	PCIe 3.0 x8
Broadcom	BCM957416A4160C	P210TP	2× 10GbE	RJ-45	PCIe 3.0 x8
Broadcom	BCM957508-P1200G	P1200G	1× 200GbE	QSFP56	PCIe 4.0 x16
Broadcom	BCM957608-P1400GDF00	P1400GD	1×400GbE	QSFP112-DD	PCIe 5.0 x16
Broadcom	BCM957608-P2200GQF00	P2200G	2×200GbE or 1×400GbE	QSFP112	PCIe 5.0 x16
NVIDIA	MCX75310AAS-NEAT	ConnectX-7 1×400G (OSFP)	1× 400GbE / NDR400	OSFP	PCIe 4.0/5.0 x16
NVIDIA	MCX75310AAC-NEAT	ConnectX-7 1×400G w/ Crypto	1× 400GbE / NDR400	OSFP	PCIe 4.0/5.0 x16
NVIDIA	MCX75310AAS-HEAT	ConnectX-7 1×200G	1× 200GbE / NDR200	OSFP	PCIe 4.0/5.0 x16
NVIDIA	MCX715105AS-WEAT	ConnectX-7 1×400G	1× 400GbE / NDR400	QSFP112	PCIe 4.0/5.0 x16
NVIDIA	MCX755106AS-HEAT	ConnectX-7 2×200G	2× 200GbE / NDR200	QSFP112	PCIe 4.0/5.0 x16
NVIDIA	MCX755106AC-HEAT	ConnectX-7 2×200G w/ Crypto	2× 200GbE / NDR200	QSFP112	PCIe 4.0/5.0 x16
NVIDIA	MCX713104AC-ADAT	ConnectX-7 4×25/50G Crypto	4× 25/50GbE	SFP56	PCIe 4.0 x16
NVIDIA	MCX713104AS-ADAT	ConnectX-7 4×25/50G	4× 25/50GbE	SFP56	PCIe 4.0 x16
NVIDIA	MCX614106A-CCAT	ConnectX-6 EN 2×100G	× 100GbE	QSFP56 ×2	PCIe 3.0/4.0 x16
NVIDIA	MCX614105A-VCAT	ConnectX-6 EN 1×200G	× 200GbE	QSFP56	PCIe 3.0 x16
NVIDIA	MCX614106A-VCAT	ConnectX-6 EN 2×200G	× 200GbE	QSFP56 ×2	PCIe 3.0 x16
NVIDIA	MCX613106A-VDAT	ConnectX-6 EN 2×200G	2× 200GbE	QSFP56 ×2	PCIe 3.0/4.0 x16
NVIDIA	MCX653105A-HDAT	ConnectX-6 VPI 1×200G	HDR 200Gb/s IB / 200GbE	QSFP56	PCIe 3.0/4.0 x16
NVIDIA	MCX653106A-HDAT	ConnectX-6 VPI 2×200G	HDR 200Gb/s IB / 200GbE	QSFP56 ×2	PCIe 3.0/4.0 x16
NVIDIA	MCX621202AS-ADAT	ConnectX-6 Dx 2×25G	2× 25GbE	SFP28 ×2	PCIe 4.0 x8
NVIDIA	MCX621202AC-ADAT	ConnectX-6 Dx 2×25G (Crypto)	2× 25GbE	SFP28 ×2	PCIe 4.0 x8
NVIDIA	MCX623106AN-CDAT	ConnectX-6 Dx 2×100G	2× 100GbE	QSFP56 ×2	PCIe 4.0 x16
NVIDIA	MCX623106AC-CDAT	ConnectX-6 Dx 2×100G (Crypto)	2× 100GbE	QSFP56 ×2	PCIe 4.0 x16
NVIDIA	MCX623105AN-CDAT	ConnectX-6 Dx 1×100G	1× 100GbE	QSFP56	PCIe 4.0 x16
NVIDIA	MCX623105AC-CDAT	ConnectX-6 Dx 1×100G (Crypto)	1× 100GbE	QSFP56	PCIe 4.0 x16
NVIDIA	MCX623105AN-VDAT	ConnectX-6 Dx 1× 200GbE	1× 200GbE	QSFP56	PCIe 4.0 x16

		1×200G			
NVIDIA	MCX623105AS-VDAT	ConnectX-6 Dx 1×200G (Secure Boot)	1× 200GbE	QSFP56	PCIe 4.0 x16
NVIDIA	MCX623105AC-VDAT	ConnectX-6 Dx 1×200G (Crypto)	1× 200GbE	QSFP56	PCIe 4.0 x16
NVIDIA	MCX631102AN-ADAT	ConnectX-6 Lx 2×25G	2× 25GbE	SFP28 ×2	PCIe 4.0 x8
NVIDIA	MCX631102AC-ADAT	ConnectX-6 Lx 2×25G (Crypto + Secure Boot)	2× 25GbE	SFP28 ×2	PCIe 4.0 x8
NVIDIA	MCX631102AS-ADAT	ConnectX-6 Lx 2×25G (Secure Boot)	2× 25GbE	SFP28 ×2	PCIe 4.0 x8

# 9. Regulatory Information

## 9.1. Safety

### 9.1.1 General

- Strictly comply with local laws and regulations while installing the equipment. The safety instructions in this section are only a supplement to local safety regulations.
- To ensure personal safety and to prevent damage to the equipment, all personnel must strictly observe the safety instructions in this section and on the device labels.
- People performing specialized activities, such as electricians and electric forklift operators, must possess qualifications recognized by the local government or authorities.

### 9.1.2 Personal Safety

- Only personnel certified or authorized by 2CRSi are allowed to perform the installation procedures.
- Stop any operation that could cause personal injury or equipment damage. Report to the project manager and take effective protective measures.
- Working during thunderstorms, including but not limited to handling equipment, installing cabinets and installing power cords, is forbidden.
- Do not carry the weight over the maximum load per person allowed by local laws or regulations. Arrange appropriate installation personnel and do not overburden them.
- Installation personnel must wear clean work clothes, work gloves, safety helmets and safety shoes.

#### PROTECTIVE CLOTHING



- Before touching the equipment, put on ESD clothes and ESD gloves or an ESD wrist strap, and remove any conductive objects such as wrist watches or metal jewelry, in order to avoid electric shock or burns.

### REMOVING CONDUCTIVE OBJECTS

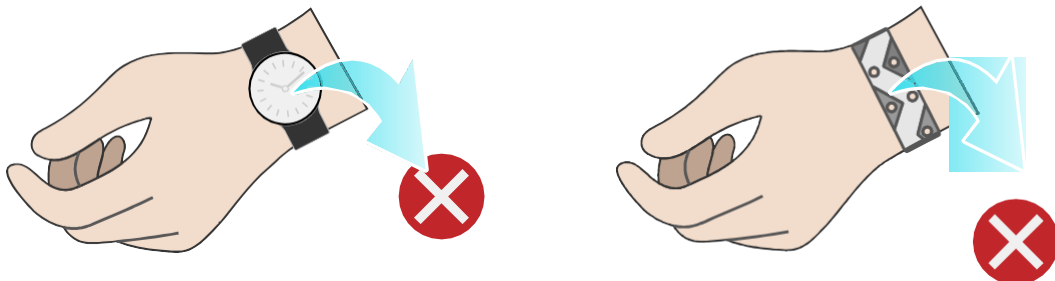

How to put on an ESD strap.

- Put your hand through an ESD wrist strap.
- Tighten the strap buckle to ensure a snug fit.
- Plug the alligator clip of the ESD wrist strap into the corresponding jack on the grounded cabinet or grounded chassis.

### WEARING AN ESD WRIST STRAP

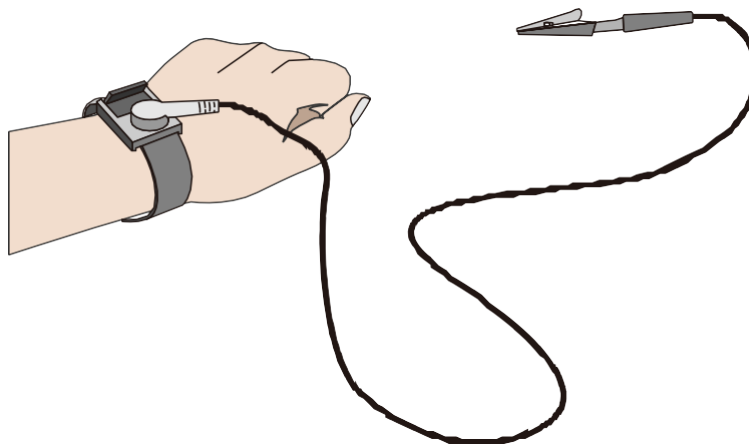

- Use tools correctly to avoid personal injury.
- When moving or lifting equipment above shoulder height, use lifting devices and other tools as necessary to avoid personal injury or equipment damage due to equipment slippage.
- The power sources of the server carry a high voltage. Direct contact or indirect contact through damp objects with the high-voltage power source is fatal.
- To ensure personal safety, ground the server before connecting power.
- When using ladders, always have someone hold and guard the bottom of the ladders. In order to prevent injury, never use a ladder alone.
- When connecting, testing or replacing optical fiber cable, avoid looking into the optical port without eye protection to prevent eye damage from laser light.

### 9.1.3 Equipment Safety

- To ensure personal safety and prevent equipment damage, use only the power cords and cables that come with the server. Do not use them with any other equipment.
- Before touching the equipment, put on ESD clothing and ESD gloves to prevent static electricity from damaging the equipment.
- When moving the server, hold the bottom of the server. Do not hold the handles of any module installed in the server, such as PSUs, fan modules, drive modules, or motherboard. Handle the equipment with care at all times.
- Use tools correctly to avoid damage to the equipment.
- Connect the power cords of active and standby PSUs to different PDUs to ensure high system reliability.
- To ensure equipment safety, always ground the equipment before powering it on.

### 9.1.4 Transportation Precautions

Contact the manufacturer for precautions before transportation as improper transportation may damage the equipment. The precautions include but not limited to:

- Hire a trusted logistics company to move all equipment. The transportation process must comply with international transportation standards for electronic equipment. Always keep the equipment being transported upright. Avoid collision, moisture, corrosion, packaging damage or contamination.
- Transport the equipment in its original packaging.
- If the original packaging is unavailable, separately package heavy and bulky components, and fragile components (such as optical modules and PCIe cards).
- Power off all equipment before shipping.

### 9.1.5 Manual Handling Weight Limits



Observe local laws or regulations regarding the manual handling weight limits per person. The limits shown on the equipment and in the document are recommendations only.

The following table lists the manual handling weight limits per person specified by some organizations.

Manual Handling Weight Limit per Person:

Organization	Weight Limit (kg/lbs.)
European Committee for Standardization (CEN)	25/55.13
International Organization for Standardization (ISO)	25/55.13
National Institute for Occupational Safety and Health (NIOSH)	23/50.72
Health and Safety Executive (HSE)	25/55.13
General Administration of Quality Supervision, Inspection and Quarantine of the People's Republic of China (AQSIQ)	Male: 15/33.08 Female: 10/22.05